

Techna STRAIGHTENERS (WIRE & STRIP)

TR - Fixed Killing Set®*

For dealing with inconsistent wire cast. Produces a constant bend before straightening process.

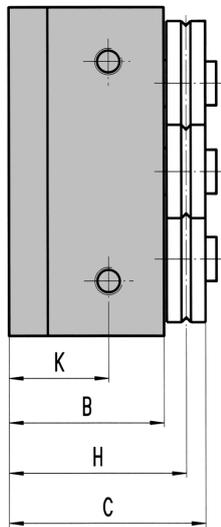
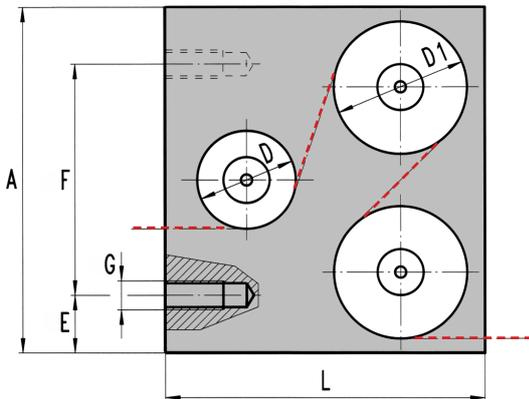

TR Series	Wire Diameter Ranges (mm) Ø				
	0 - 0.3	0.3 - 0.5	0.5 - 0.8	0.8 - 1.5	1.5 - 3.0
Order Ref.	TR3-0.3	TR3-0.5	TR3-0.8	TR3-1.5	TR3-3.0
A	32	40	60	80	100
B	20	29	28	33	37.5
C	23.5	34.5	35.5	40.5	48
D	10	13	17	23	31
D1	13	17	23	31	40
E	4.5	10	10	10 / 25	10
F	23	20	40	60 / 30	80
G	M4	M5	M5	M6	M8
H	22	32	32	37	43
K	15.5	19	18	23 / 10	27.5
L	25	40	55	70	90
Kg	0.1	0.4	0.8	1.5	2.7

TRV - Adjustable Killing Set®*

Allows a range of bend radii to be produced.

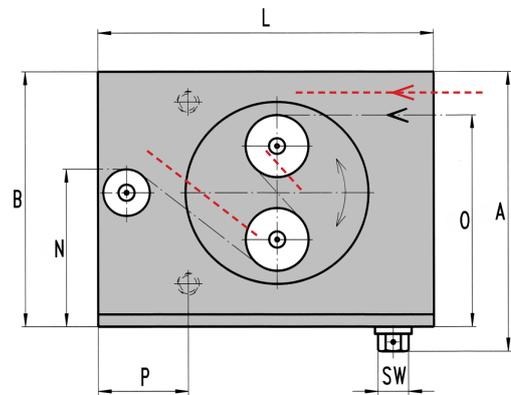
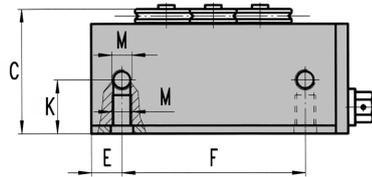
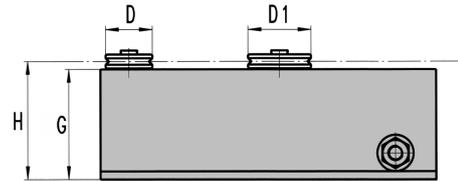

TRV Series	Wire Diameter Ranges (mm) Ø			
	0 - 0.5	0.5 - 0.8	0.8 - 1.5	1.5 - 3.0
Order Ref.	TRV3-0.5	TRV3-0.8	TRV3-1.5	TRV3-3.0
A	107	107	138	138
B	95	95	126	126
C	49.5	51.5	61.5	63
D	13	17	23	31
D1	17	23	31	40
E	10	10	15	15
F	70	70	90	90
G	44	44	54	52.5
H	47	48	58	58
K	24	24	26.5	26.5
L	125	125	165	174
M	M8	M8	M10	M10
N	57	58	76.5	80.5
O	69.5	77	103.5	113
P	32.5	32.5	40	50
SW	13	13	13	13
Kg	3.5	3.5	8	9

* Killing Sets use heavy duty WICAS Rolls (see details on page 98)